

# Subtractive Perspective Drawing – ILA 4 : Adapting Forms/ Subtractive

This ILA was a lot of fun, because I really like perspective drawing. However, it was also a challenge, especially in forms like the one with all the little cubes where a lot of perspective work had to be done. It's also interesting to see how much variety you can get from just removing cuboids from (almost) the same base cuboid.

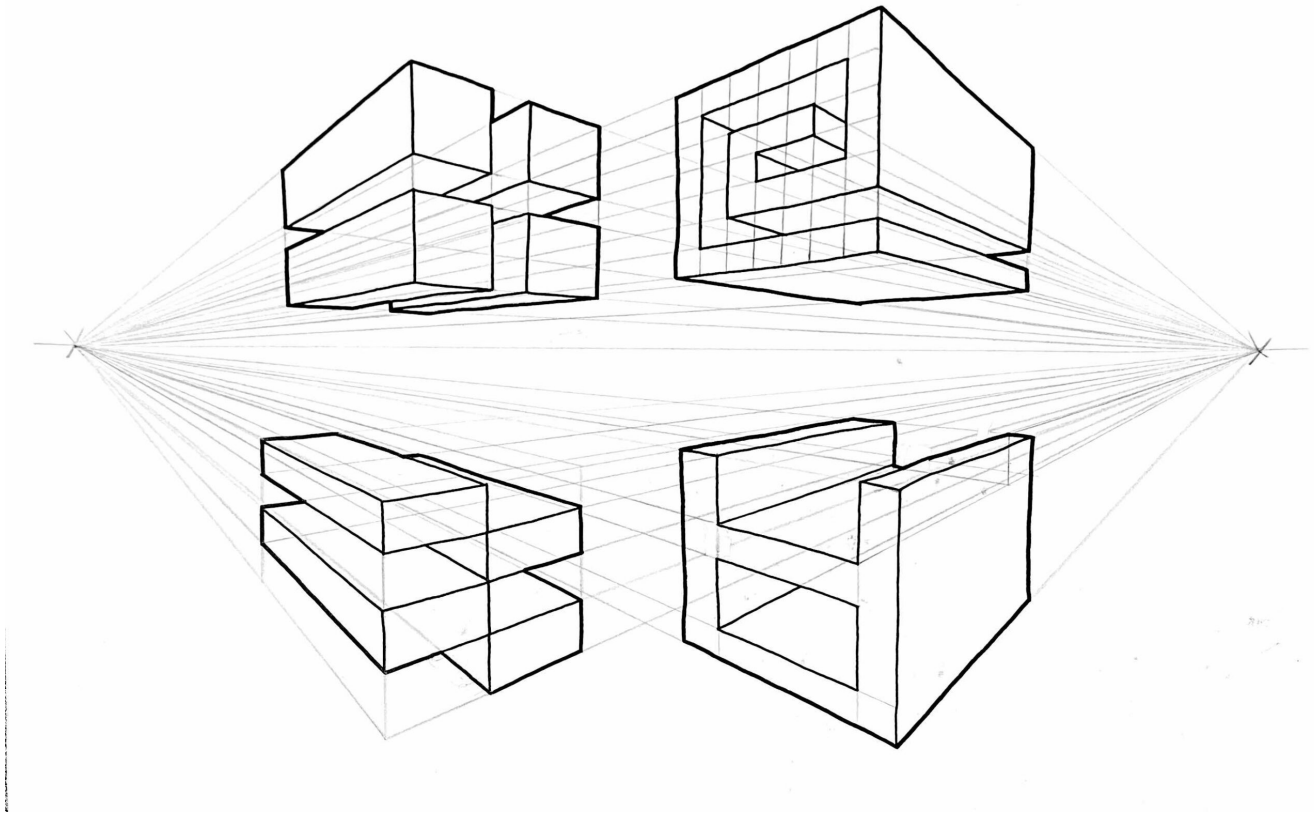

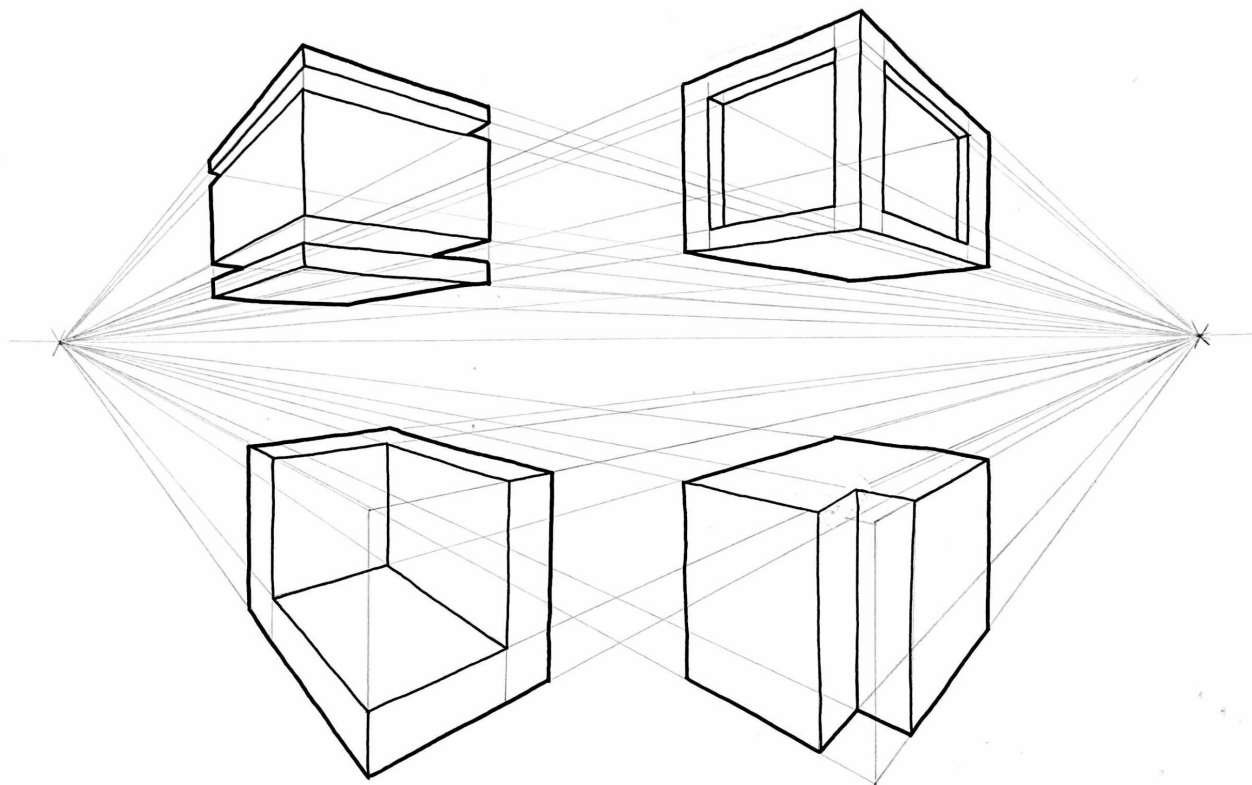

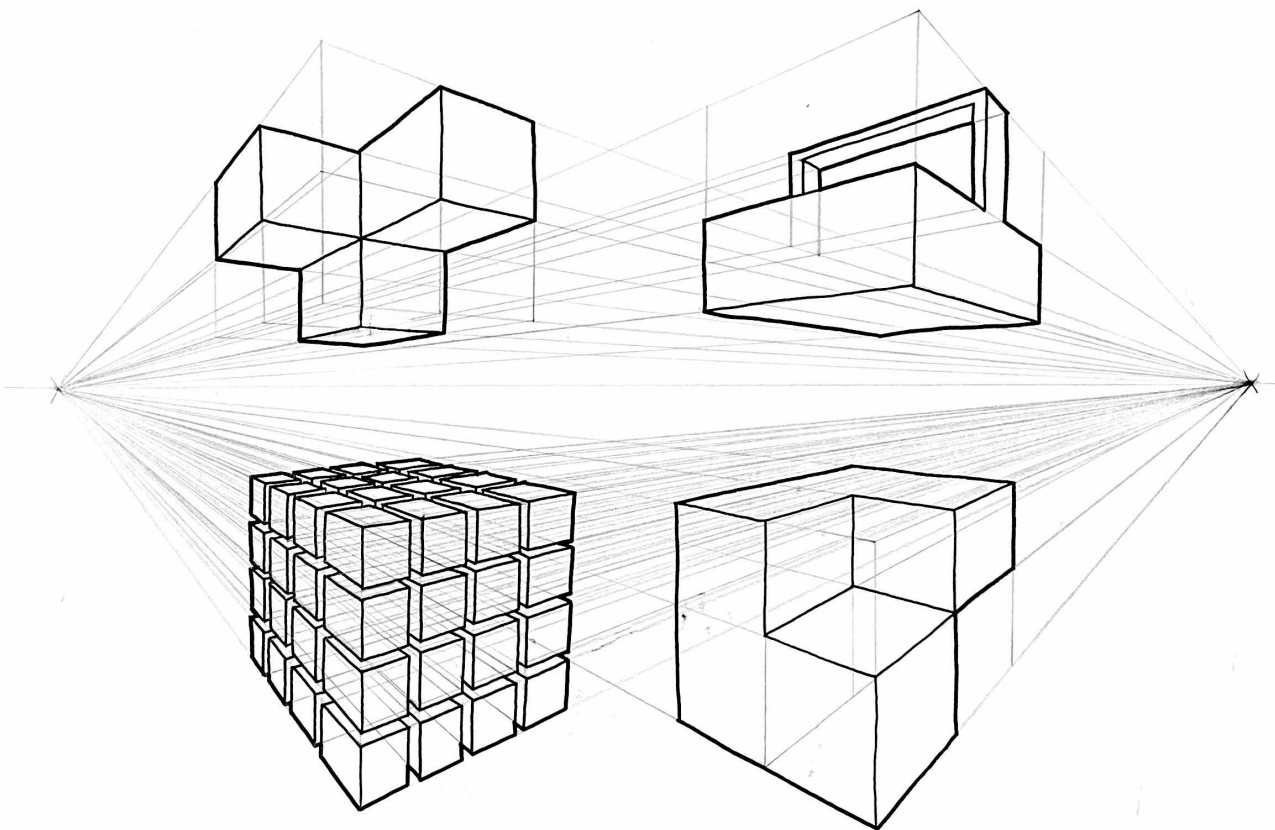
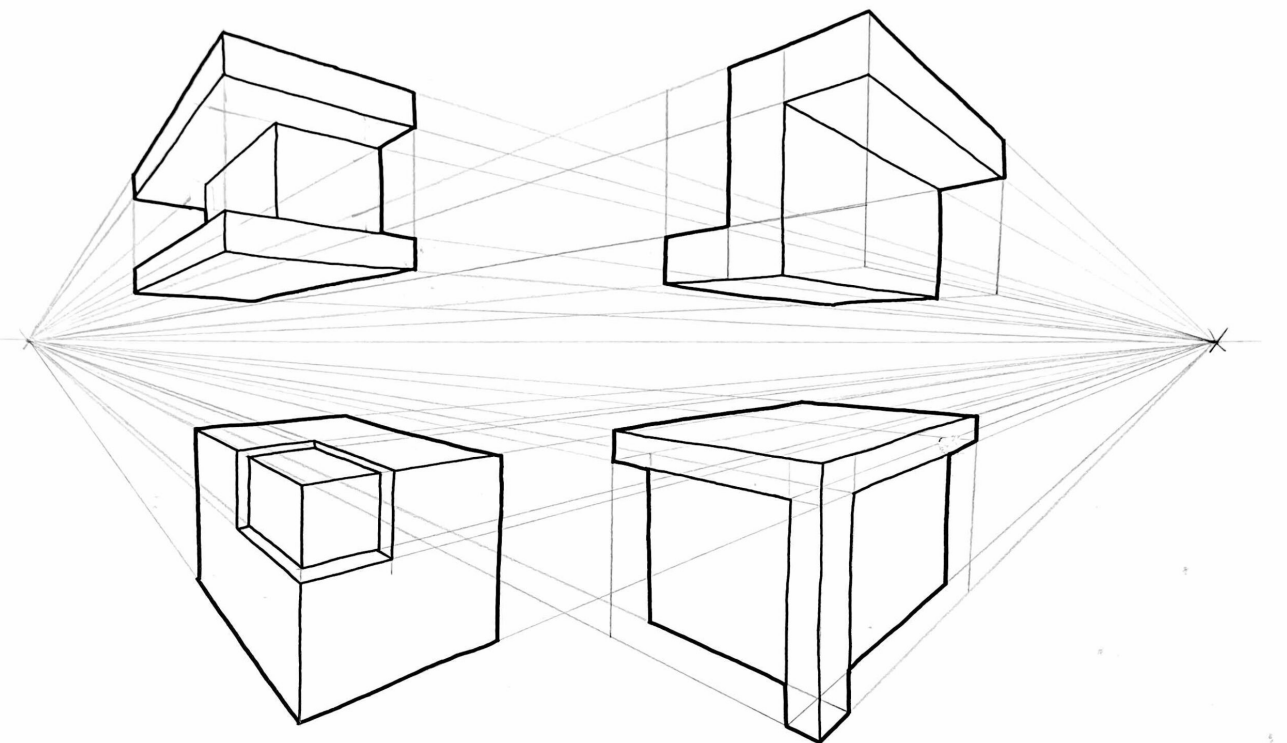
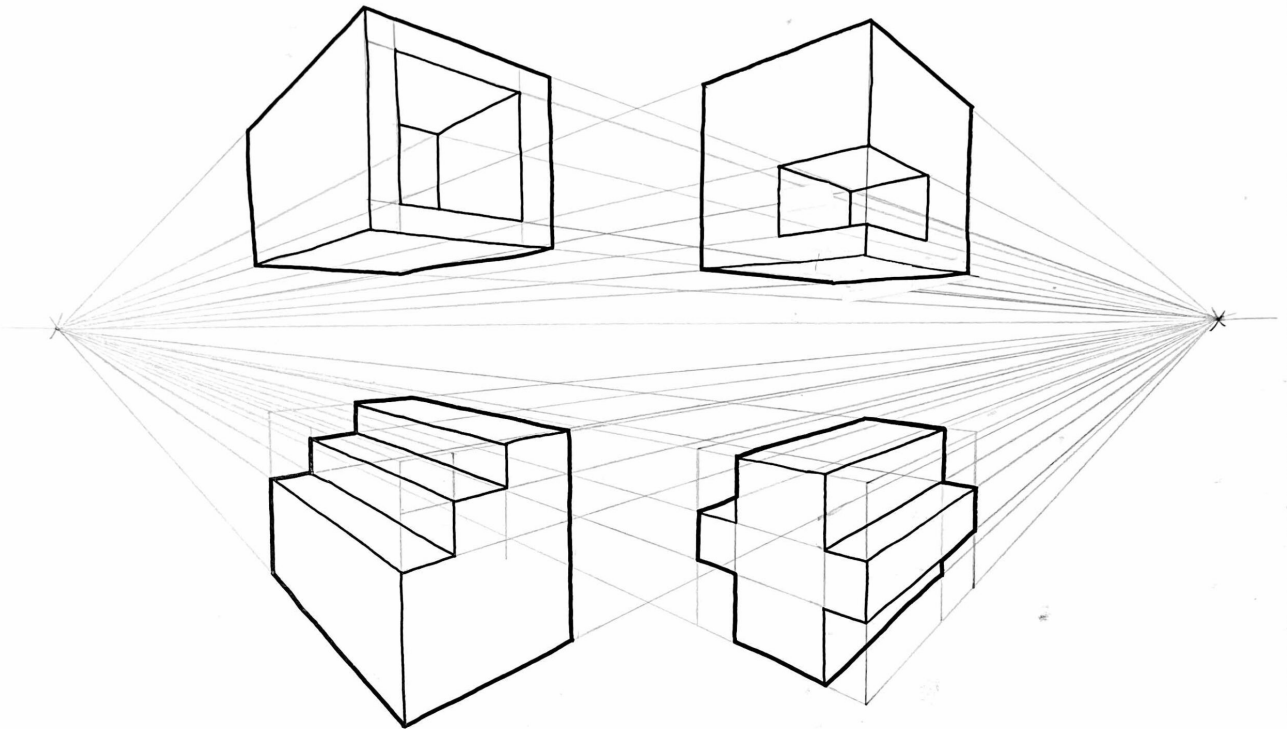

I then took four of these, and redrew them without the pencil lines and with color, which really brought them to life in a sense, and actually brought them from 2D to 3D.

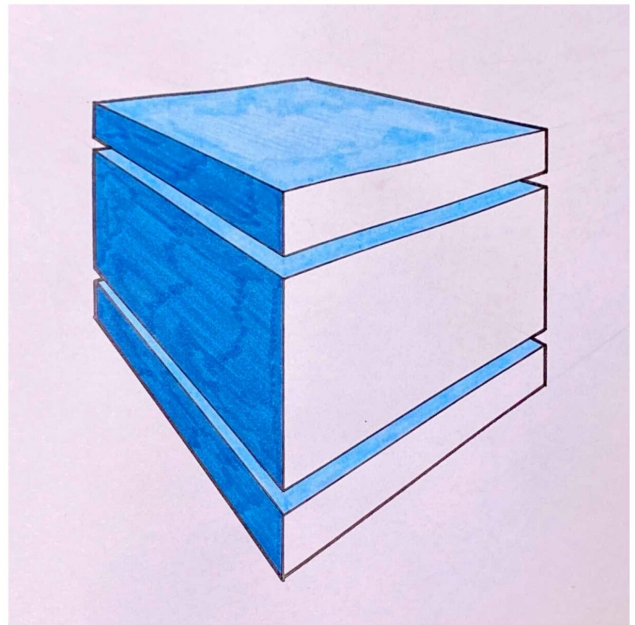
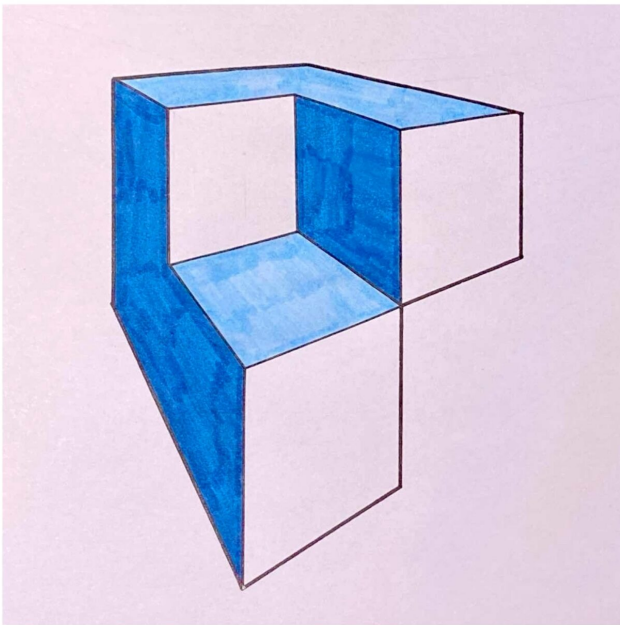
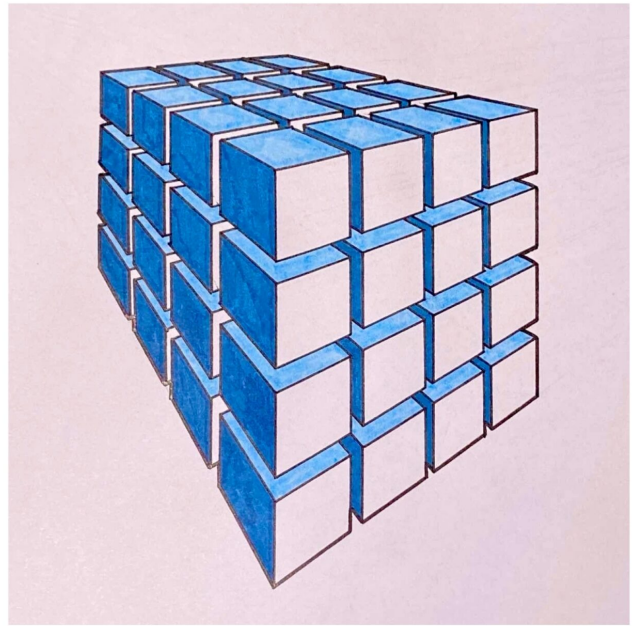
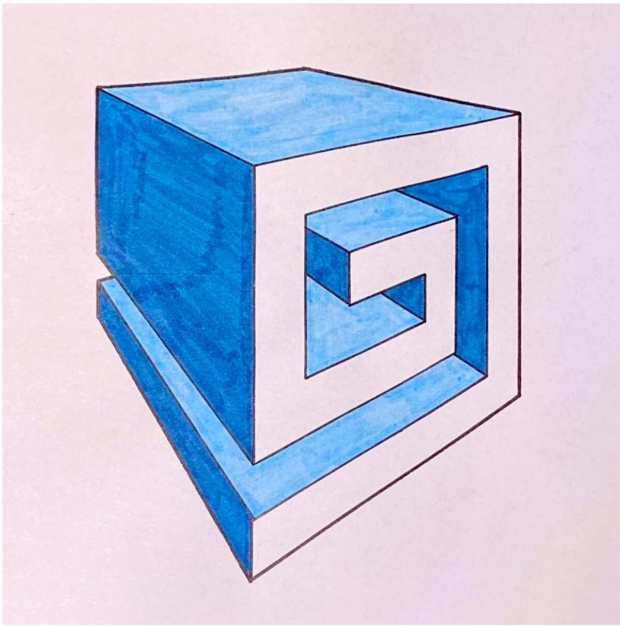

This was also a good opportunity to try the Photoshop tutorial for cleaning up images after scanning (See images below). Though this worked well with the background, I still need to practice more as the colors turned out a bit weird.

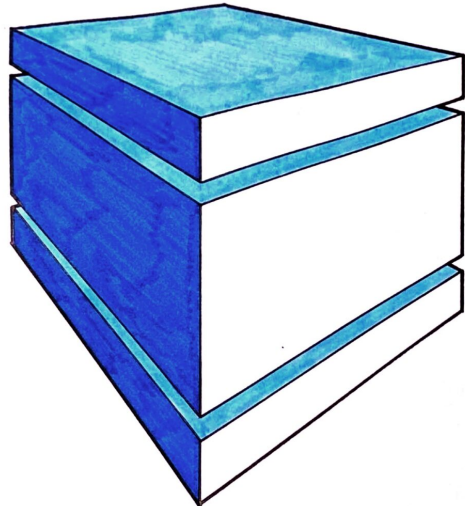
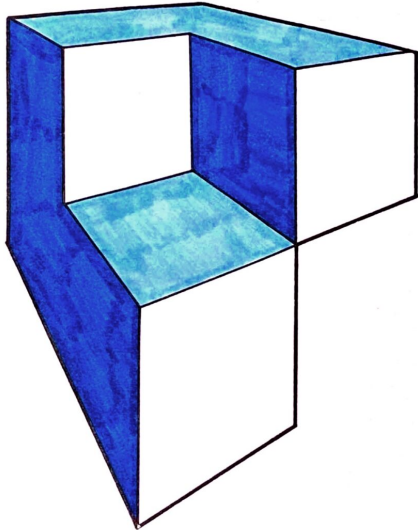
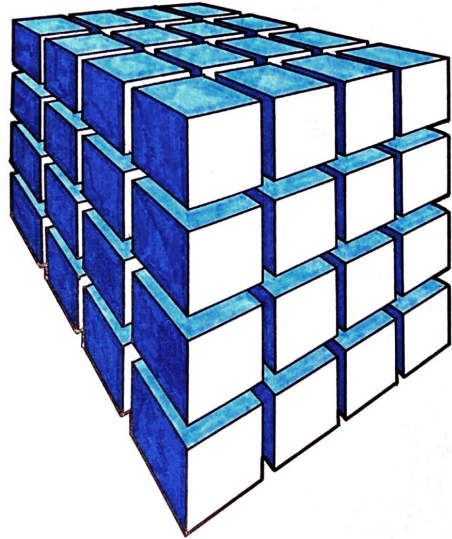
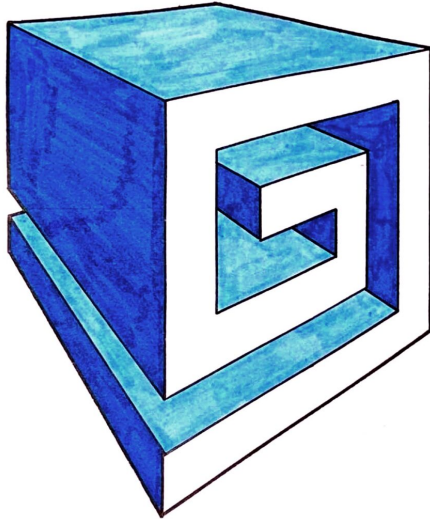

Out of curiosity, I made a few extra ones, seeing what it would be like if the shapes I subtracted were not cuboids. This was to an extent harder to work with, especially when it comes to ellipses which i find challenging to draw, however it was a fun little extension.



